

AANZICHT AS- H + I

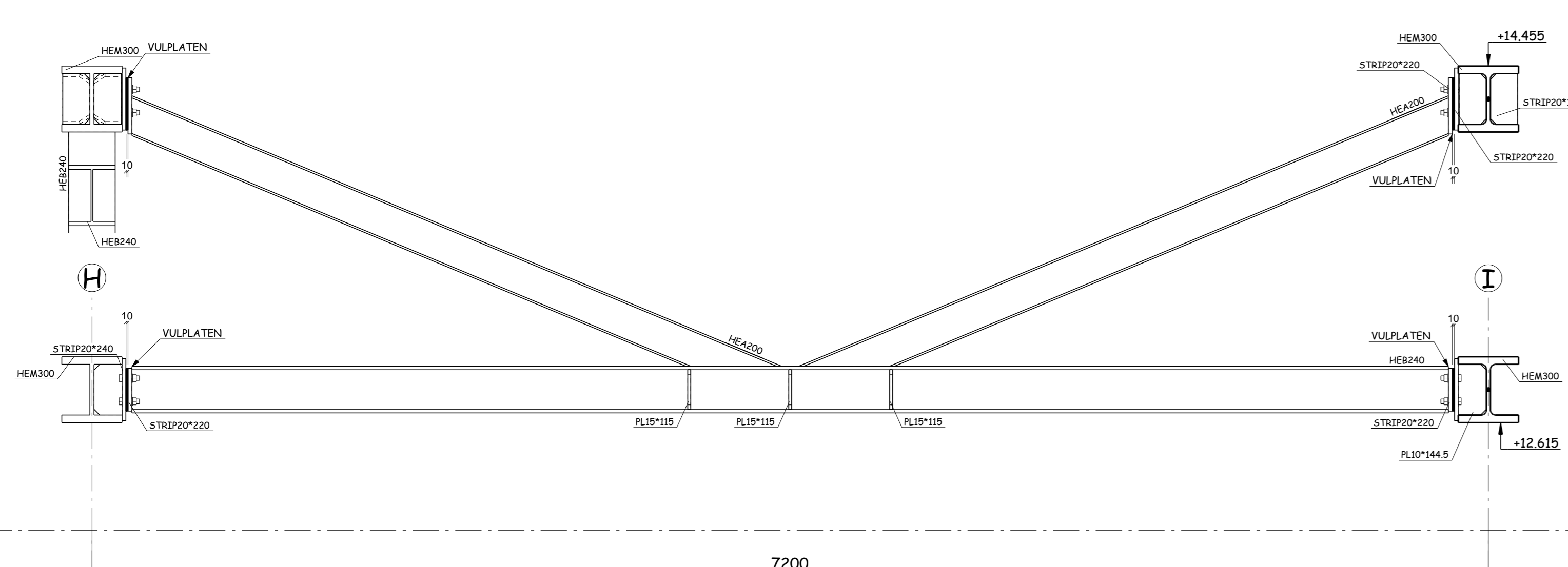

AANZICHT TUSSEN AS- 1 + 2

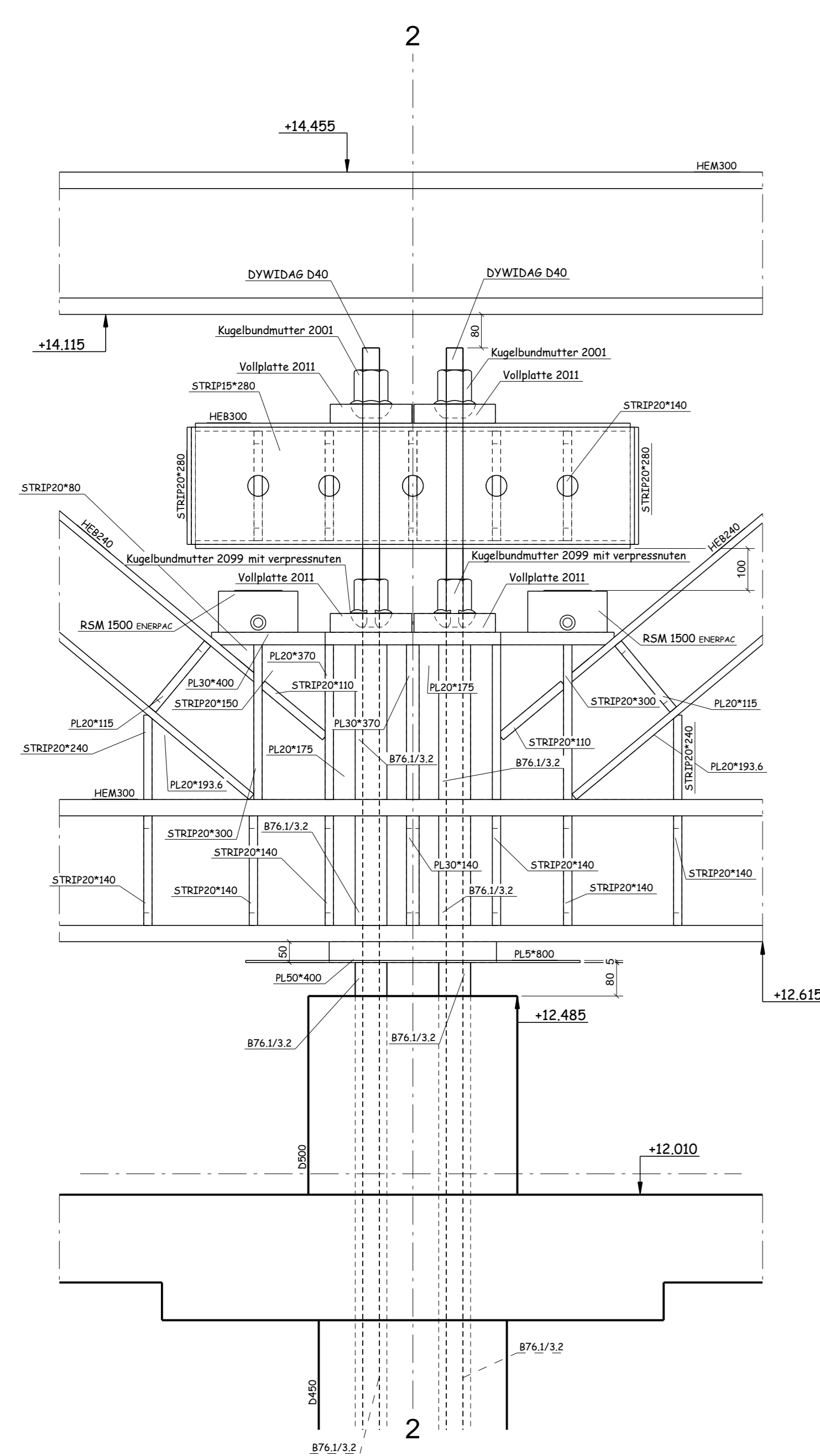
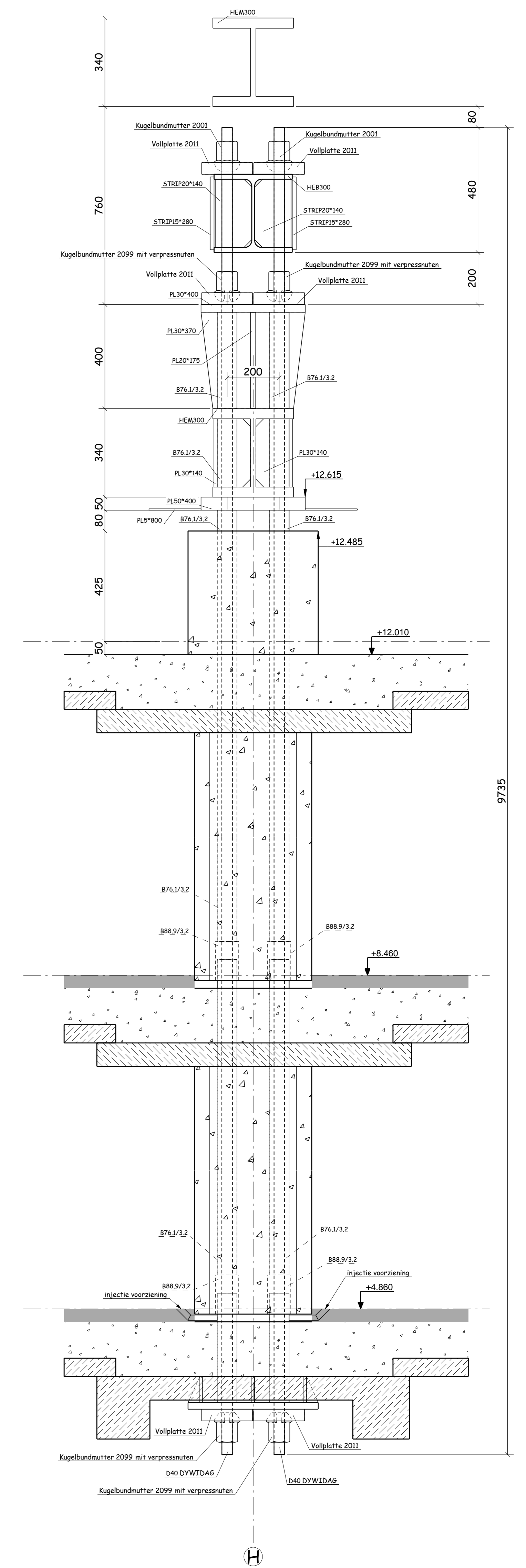
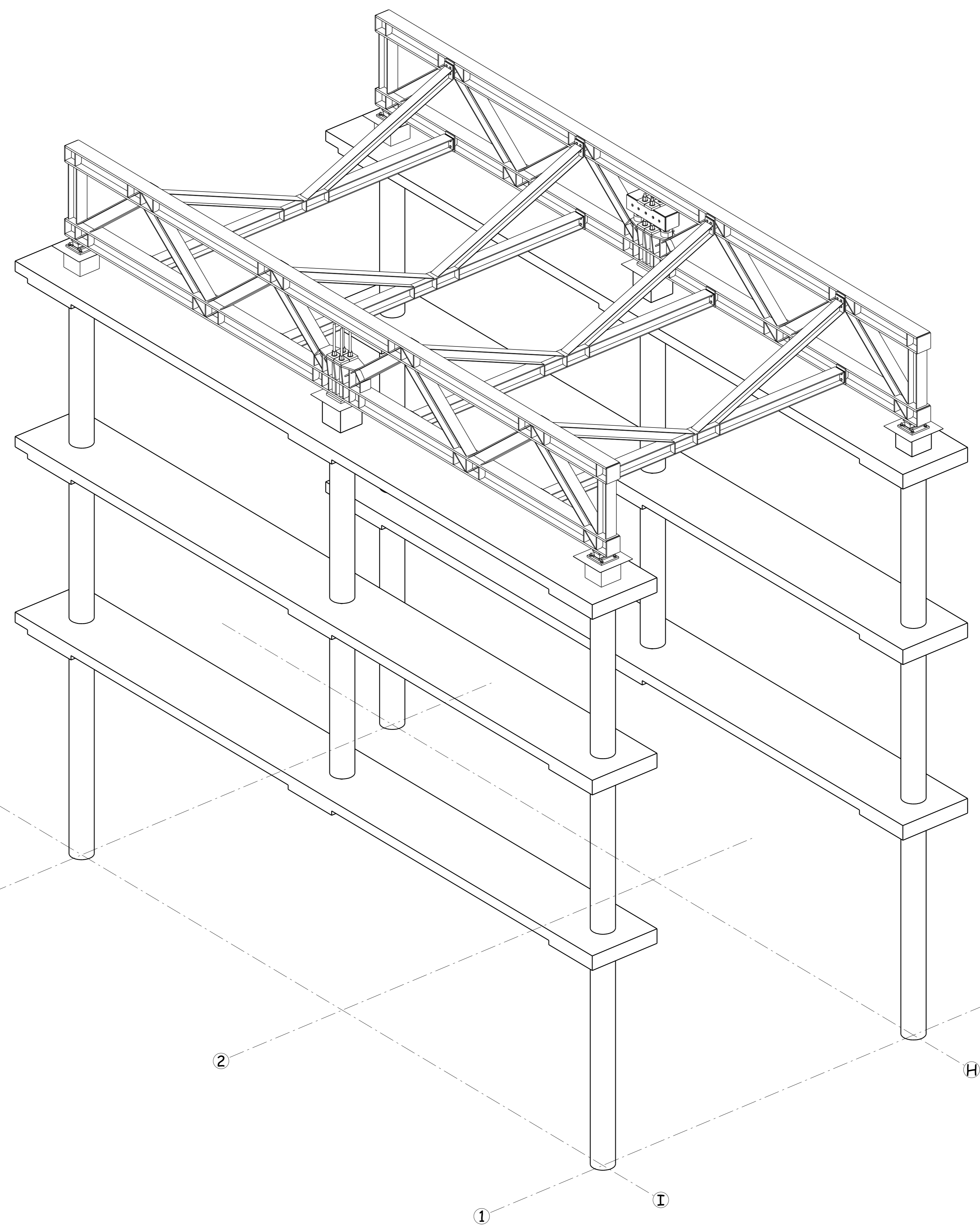

DETAIL VIJZELS

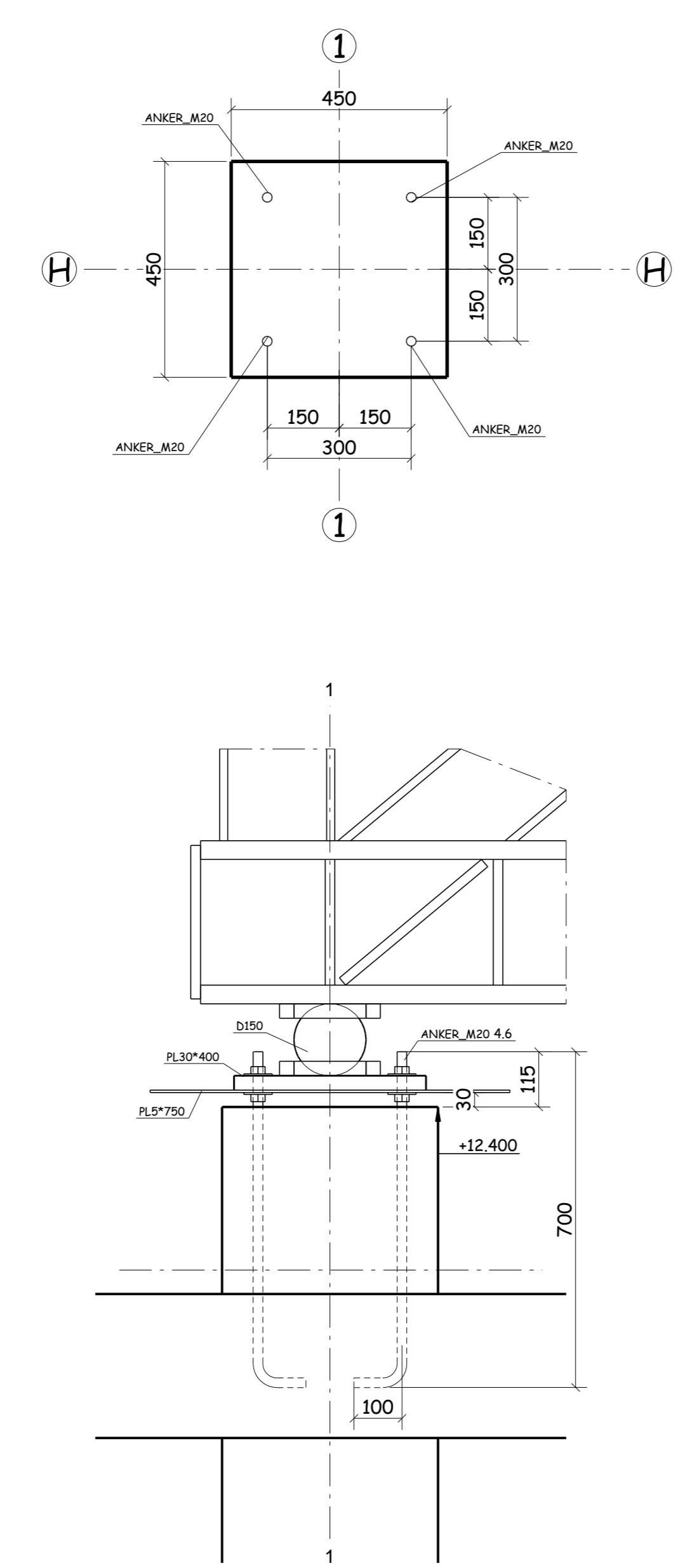

DETAIL ANKERS

2 B	DEFINITIEF	14-09-2006
1 A	TER CONTROLE	25-08-2006
	REVISIE: REVISIE OMSCHRIJVING:	DATUM:

HTB H.TEN BRINKE & ZN
 CONSTRUCTIEBEDRIJF
 KEMPENWEG 2 7415 SA MARNELO
 TELEFOON 0647-381008
 TELEFAX 0647-363916

Materialbehandeling:	THEERMISCH VERZINKEN - POWDERCOATEN RAL7035
Materialdikte:	5235, lokers 5275 tenzij anders vermeld
Boortdikte:	8,8 tenzij anders vermeld
Haakankers:	kwal 4.6 grotte draad, tenzij anders vermeld

Plan:
 Aletta College Hoogezand
 Onderwerp:
Details Dywidag
 Opdrachtgever:
 Trebbe Bouw Oost & Noord B.V.

klurakon bv
 ADVISBURO VOOR STAALCONSTRUCTIES
 Postbus 140, 7060 AC Tetering
 Tel: 0315-344950 Fax: 0315-329807 E-mail: info@klurakon.nl

Schaal: 1/10 1/20 1/40
 Ger.: Klurakon
 Formaat: 1189x841
 Onder: 06-43

G | 2 |
 TEKENINGNUMMER:
 B
 2